



**DIVE GEAR EXPRESS**

**DGX Gears D6**

**Second Stage Service Manual**



Copyright © 2022 Dive Gear Express  
All Rights Reserved.  
Revision 2 Published 09/23/2022

Revision	Date	Changes
1	02/19/2021	Initial publication
1a	03/25/2022	Replaced photo for Fig. 28
2	09/23/2022	Minor technical edits for clarity; replaced Fig. 3, removed Figs. 4 and 5 and renumbered subsequent Figs.; replaced Figs. 24, 25, and 26

# 1. Overview

(1) The availability of subassemblies and components, repair parts, specialized tools, and maintenance manuals does not imply qualification to assemble and/or service scuba equipment. Improper service of dive equipment can lead to severe injury or death. Dive Gear Express recommends that non-qualified individuals seek professional training/mentoring before attempting repairs or servicing on any diving equipment.

**Failure to follow the procedures outlined herein may result in serious injury or death!**

(2) In the following pages will be found the disassembly, assembly, tuning and troubleshooting steps for these components. Photos are used throughout to illustrate the procedures.

**Please pay special attention to all Caution Notes!**

(3) Whenever an item of extra importance needs to be observed, a "Caution Note:" will appear, followed by the required information. See below.

**Caution Note: This must be read and followed!**

(4) Included in this manual is a list of recommended/required tools for each disassembly, assembly, and testing section. They are identified in each section where they are used.

(5) A schematic diagram is located at the rear of this manual. The diagram contains the detailed parts lists. The diagram also includes the torque specifications for parts where required.

(6) A general troubleshooting guide with space for notes is also included for those using a printed version. Those who prefer an electronic version should keep detailed notes in an accessible location for their own observations and service tips, as well as a record of service.

(7) Throughout the text, parts are referenced using the item number on the schematic to facilitate locating each individual component.

(8) Parts should not be taken out of their packaging until the actual assembly stage is reached, and the user is ready to lubricate, where necessary, and install them.

(9) Ensure the service area is free of any environmental factors that may cause problems during the servicing of your regulators. The area must be clean and organized. The use of nitrile gloves is highly recommended for final rinsing and assembly. This will minimize the risk of skin oils contaminating the internal components of the regulator.

(10) Ensure that all required servicing/testing air supplies are available and at the proper test pressures if not using a regulated supply from a single source. **"Modified Grade E" air as typically delivered at a dive shop fill station is preferred.**

**Caution Note: Only use air from a breathing air source! Do not use a hardware store shop compressor.**



## **Cleaning and Rinsing - General Considerations**

- (11) Cleaning and rinsing of the components should be done using clean, fresh water.
- (12) Only use degreasers that leave no organic residue (e.g., Extreme Simple Green, Blue Gold Cleaner, or any clear liquid dish soap that does not contain scents or dyes).
- (13) To remove corrosion, use a 50/50 vinegar/water solution and nylon brushes. Areas of heavy corrosion not removed with vinegar can be addressed with mild phosphoric acid solutions available from scuba supply houses.
- (14) Allow parts to air dry without the use of loop-weave cloths that may leave fibers.
- (15) Once all service procedures have been completed and bench testing done, in-water testing in a confined environment such as a swimming pool is recommended to confirm proper function before taking the regulator on an actual dive.

## Cleaning of Regulator Parts

(16) Cleaning of parts that are going to be reused is one of the most critical steps in servicing the regulator. As was stated earlier, use the proper solutions for the job at hand. Removal of hydrocarbons and debris should be accomplished before attempting removal of corrosion. Areas of corrosion are often also coated with old lubricant or oily contaminants. Before attempting to remove corrosion, use warm detergent and a soft brush to remove oils and debris. Then use an acidic solution to remove corrosion. Once corrosion has been removed, inspect parts and repeat detergent washing as needed. Wearing nitrile gloves throughout the process reduces the risk of contaminating the parts with skin oils.

(17) First, prepare a warm solution of detergent from the list above. Immerse both plastic and metal parts and agitate thoroughly. Protect critical delicate parts (such as the Orifice) by washing them separately or isolating them in a small plastic container with holes. Wash the diaphragm separately, using your fingertips to remove debris. Use a soft nylon brush and/or soft rags soaked in detergent to scrub away visible debris and contaminants. Corrosion will likely not be removed during this step. Rinse repeatedly in clean water.

(18) Now address visible corrosion by submerging **metal parts only** in a 1:1 dilution of white vinegar and hot water. Do not immerse plastic parts in an acid bath - it will degrade the plastic and make it more susceptible to cracking. Agitate the parts occasionally and allow parts to stand in the acidic solution for ten minutes. Wearing gloves, remove and inspect parts, and reimmerse them for an additional ten minutes if visible corrosion is still noted. Removal of corrosion will leave bare brass behind, which will not affect regulator function, but will necessitate more frequent future inspection and service. After the acid bath, rinse all metal parts thoroughly.

(19) Best practice is to neutralize any possible residual acid remaining in crevices and threads, by immersing all acid-treated parts in a neutralizing solution of warm water and sodium bicarbonate (baking soda) in a ratio of 1 tablespoon per gallon of water. After a brief neutralizing soak, again rinse all parts thoroughly. In areas with high mineral content in the water, a final rinse with distilled water should be considered. A plastic colander is excellent for drainage after rinsing. For very small parts, a mesh strainer for sink drains works well. Often sold as a set, they are inexpensive and can be used for many types of regulator components. Again, protect delicate parts from contact with hard metal surfaces. Retained final rinse water should be allowed to stand and examined for a surface sheen indicative of residual hydrocarbon residue. If noted, return to step (17) above.

(20) After washing and rinsing the regulator parts, allow them to air dry. Using a drying rack will facilitate this. Do not lay the parts on a paper towel or loop-weave cloth towel. Doing so runs the risk of having fibers stick to them that will cause issues with sealing. If a cloth is used as an aid to drying, make sure to use a tight, flat weave lint-free cloth that has previously been well washed to remove fabric sizing.

## Inspection After Cleaning

(21) Before assembling the regulator, it is necessary to inspect all the cleaned components. Using a magnifying glass or inexpensive USB microscope, ensure all parts are clean and contaminant-free, and check the components for damage that may have been hidden by corrosion or lubricant. Look for scratches that may affect the sealing surfaces of the regulator.

(22) Lay all parts out on a padded work surface following the schematic. A rubber or silicone mat of suitable size that is clean and free of contaminants works well for this.

(23) Now that all parts have been cleaned and checked, the assembly can begin. Remove the new parts from the service kit bag and lay them out following the schematic, matching them to the old parts for size. Then make sure all old parts that are to be replaced have been discarded or segregated.

**Caution Note: Removing parts from their packaging, before they are to be used, runs the risk of mixing them up. Some O-rings are very close in size but are not interchangeable! Keep the parts in their packaging until you are ready to exchange them for their used equivalent.**

(24) As with the parts that have been cleaned, it is a good idea to inspect the new parts as well. Inspect the LP Seat to ensure it is free of any defects. Check all the O-rings and inspect them as you use them for nicks or imperfections. Inspect the washers to ensure they are free of burrs or other defects that could affect their function. It is critical to use the parts list on the schematic to ensure that all new parts are present and accounted for in their required quantities.

(25) **Lubrication can be overdone.** Doing so runs the risk of trapping excess dirt or debris on the parts. One way of reducing the risk of overdoing it is to use the lube-in-a-bag method - Fig. 1



Fig. 1

This involves using a small clean plastic bag containing a small amount of lubricant. The O-ring is inserted into the bag, worked around to evenly coat with lube while squeezing off excess, then taken out of the bag and used in its location - Fig. 2.

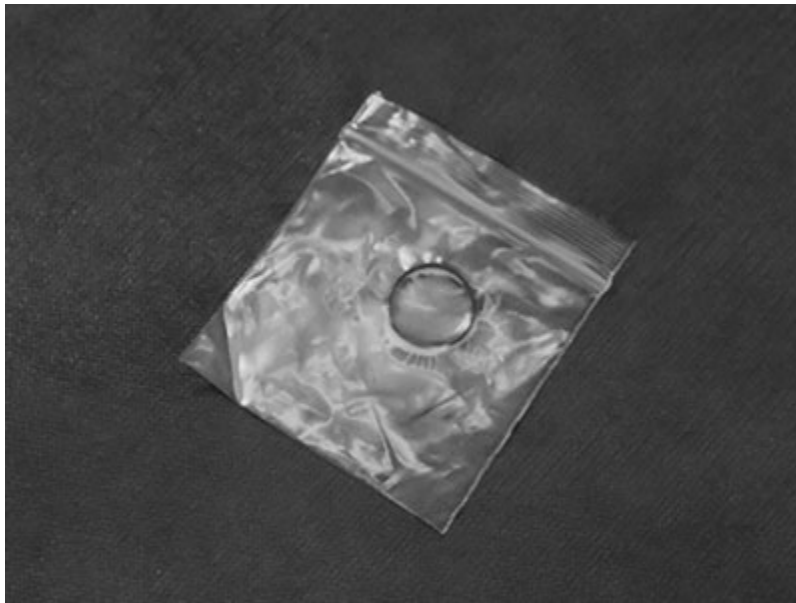

Fig. 2.

(26) Another way is to apply a small amount of lubricant to the gloved index finger and massage the O-ring between the thumb and index finger.

(27) **Under most circumstances, a lubricant should be used very sparingly or not at all.** In nearly all scuba applications, if you can see the lubricant, too much has been applied. Before using any lubricant, any existing lubrication should be removed before new is applied. In dynamic applications, it is used to reduce excessive wear. Static O-rings do not generally require the use of lubricant.

(28) Do not unnecessarily lubricate parts. Certain parts are specifically noted to be installed without lubrication. It also helps to keep those parts clean and free of debris that will cling to the lubricant. Not lubricating unnecessarily helps to keep those parts clean and free of debris that might otherwise cling to the lubricant.



## 2. Tool List - Fig. 3

1. Magnehelic or Other Cracking Effort Gauge
2. Side-Cutting Snips
3. Thin Adjustable or Open End Hose and 11/16" Wrenches
4. 3/16" Hex Key
5. Thin Brass Pick
6. Blunt Brass Pick and Blunt Brass Spade
7. Thin Wooden Dowels
8. Second Stage In-Line Adjusting Tool (Hex Adjusting Tip)



Fig. 3

(1) The In-Line Adjusting Tool with IP Gauge and Brass O-Ring Pick Set can be found at Dive Gear Express using the link below.

<https://www.divegearexpress.com/tools/scuba-tools>

(2) Tools may also be purchased from Scuba Tools at the link below.

[www.scubatools.com](http://www.scubatools.com)

(3) Additional useful items are a magnifying glass or inexpensive USB microscope, nitrile gloves and, to aid in rinsing, a plastic colander and small mesh strainers for smaller parts.

### 3. Preliminary Testing

(1) Preliminary testing of the regulator is necessary to identify any problems with the first and second stages and verify overall regulator function. This testing will include:

1. Visual inspection of the regulator
2. Inspection of the hoses
3. Cracking effort and negative pressure test

Visual inspection is done to identify issues that could affect servicing and to ensure that pressurizing the system will not compromise the safety of the service technician.

Check all connections to make sure they are secure.

Check that on the first stage, there are no extruded O-rings, and hoses are tight.

Detailed inspection of hoses is done to ensure it is safe to pressurize the regulator set. Look for evidence that might lead to hose failure. Check all hose connection crimps. Defects must be taken care of before pressurizing the system! Replacement of any suspect hoses is recommended.

**Caution Note: Defects in hoses require replacement before pressurizing the regulator! Failure to do so may result in serious injury!**

(2) The Intermediate Pressure (IP) of the first stage should be confirmed before testing the second stage.

(3) The standard operating range for the system is with an IP of 135 psi.

## 4. Second Stage Evaluation

(1) The negative pressure test verifies the seals of the Diaphragm and Exhaust Valve, confirms proper O-ring seal and verifies housing integrity. With the supply pressure off, and attached to a first stage on a cylinder, attempt a normal breath from the second stage. You should be unable to draw any air. If flow is obtained, remove the second stage from the hose and try to draw air while sealing the hose inlet with your finger. If a flow is still present, the Diaphragm and Exhaust Valve need to be checked for damage. Salt accumulation, sand, and defects in the housing or O-rings may also allow airflow when the air inlet is covered. Carefully check all of these.

(2) Cracking effort testing is most accurately done with the use of a magnehelic gauge. A container of water can be used by measuring the depth to which a stage can be submerged face-down parallel to the water. This gives an indication at which level of effort the second stage will open. The normal range for the adjustable second stage is 1.0 to 2.2 inches of water. Less pressure may be desired by the diver, but the initial factory setting of 1.1 should be used. This permits a break-in period for the LP seat. It is normal to see this initial setting drop as the LP seat takes a set.

(3) The housing should be inspected for signs of damage. Scratches, gouges, missing parts, damaged exhaust ports, or a loose faceplate that will not tighten may be an indication of a damaged housing.

(4) After the negative pressure test, test the purge button, and look for defects. Check the lever and breathing effort knob. Do they move freely and with no indication of stiffness? Do they feel like there is sand or grit in them?

(5) A problem with housing integrity should be dealt with before starting the rebuild. A defective housing will compromise final testing and pose a safety hazard to the user.

**Caution Note: A damaged Main Housing, Top Cover, or Diaphragm cannot be repaired. They must be replaced.**

(6) Having completed the initial evaluation and determined that service is necessary, the rebuild of the regulator can take place.

## 5. Second Stage Disassembly

(1) Additional tips for performing disassembly of the D6 Second Stage can be found in our video at:

<https://www.youtube.com/watch?v=W12VDuCKOCE>

(2) Ensure the system is depressurized. The use of small, clean containers to hold parts is recommended.

(3) In the following steps, the part numbers from the schematic will be used with their description. The numbers on the photos also correspond with the parts list on the schematic. Items in the service kits are identified in the same way. Have both in front of you while following the instructions. Be sure to keep all old parts organized and separate from new ones in the service kit. The old washers and O-rings marked with an asterisk (\*) will be replaced with new ones from the service kit and the remaining parts will be cleaned and reused. Take care with O-ring (04\*) and O-ring (20\*) as they are very close in size.

1. Remove the Second Stage from the hose. The Main Housing cover consists of the Purge Button Retainer (08), Purge Button (09) and Top Cover (10). Unscrew the cover from the Main Housing (01) - Fig. 4. Remove the Diaphragm Washer (07) and the Diaphragm (06). This reveals the Adjust Tube assembly in the Housing - Fig. 5.



Fig. 4



Fig. 5

2. Remove the Heat Sink Nut (05) - Fig. 6. Holding the Lever (18) down, slide/pull the Adjust Tube assembly out of the Main Housing as one unit - Fig. 7. Inspect the Exhaust Valve (11\*) by using a pick or dowel and gently press all around the edge to check that it is pliable and not stuck or torn. – Fig. 8.



Fig. 6



Fig. 7



Fig. 8

3. Slide the Deflector Knob (16) off the assembly while holding down the Lever - Fig. 9. After sliding the Deflector Knob off, carefully allow the Lever to come up slowly. Remove the O-ring (15\*) from the Deflector Knob and O-ring (04\*) from the inlet side of the Main Housing - Fig. 10.

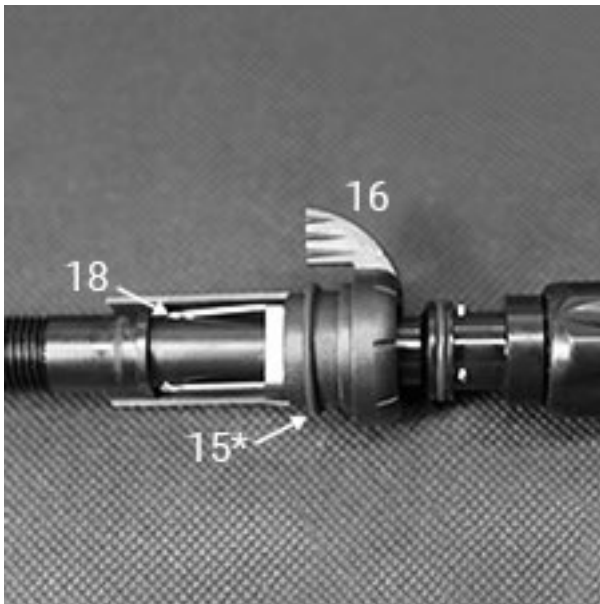

Fig. 9

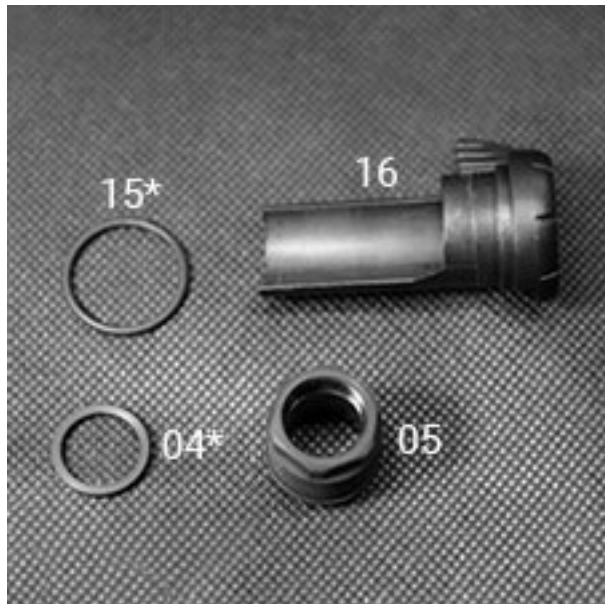

Fig. 10

4. Turn the Adjust Knob (27) slightly with the assembly over a flat surface, allowing the Pin (19) to drop out - Fig. 11. This will allow the Adjust Knob to be removed. Remove the O-ring (20\*) from the Adjust Tube (17) - Fig. 12.

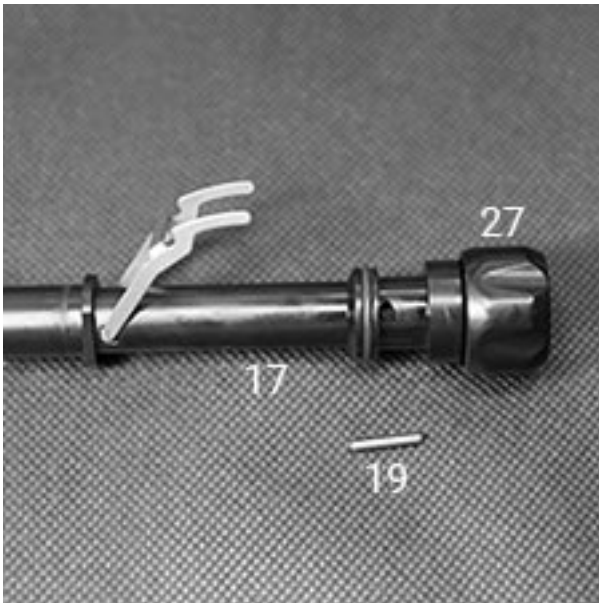

Fig. 11

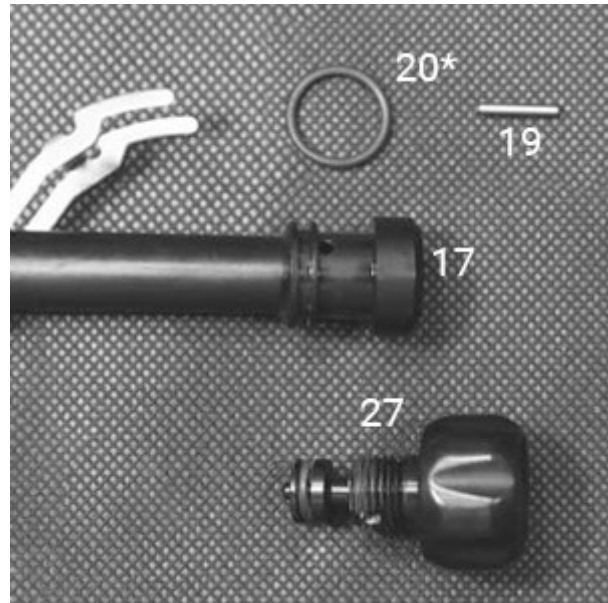

Fig. 12

5. Remove the Knob Adjust Core (29) from the Adjust Knob with a pick. Insert the pick and pop the core out - Fig - 13. Remove the O-ring (26\*) from the Adjust Knob. Remove O-rings (28\* and 30\*) from the Knob Adjust Core - Fig. 14.



Fig. 13

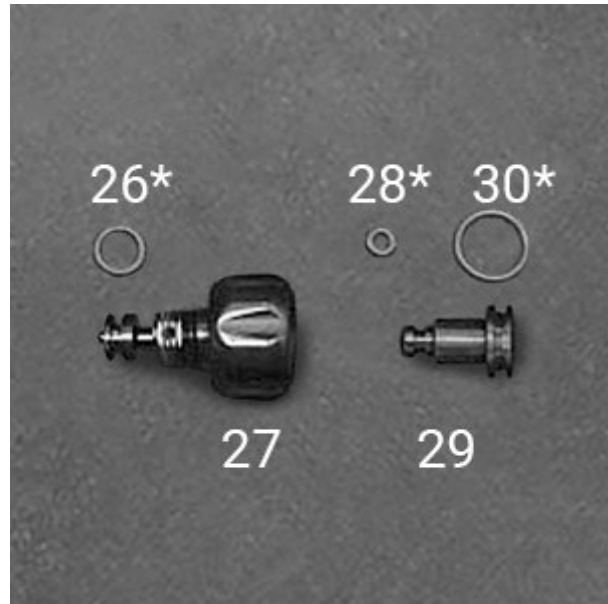

Fig. 14

6. Holding the Lever upright, use a thin wooden dowel to push the assembly consisting of the LP Seat (21\*), Piston (22), O-rings (23\*), Main Spring (24), and Balance Cylinder (25) out of the Adjust Tube. You may hear a slight click as you do this when the LP Seat end passes the Lever. Remove the Lever from the Adjust Tube - Fig. 15. An alternative method is to carefully remove the Lever by lifting one leg out of the hole and rotating the Adjust Tube to allow the other side to come out - Fig 16. DO NOT BEND THE LEGS OF THE LEVER TO DO THIS.

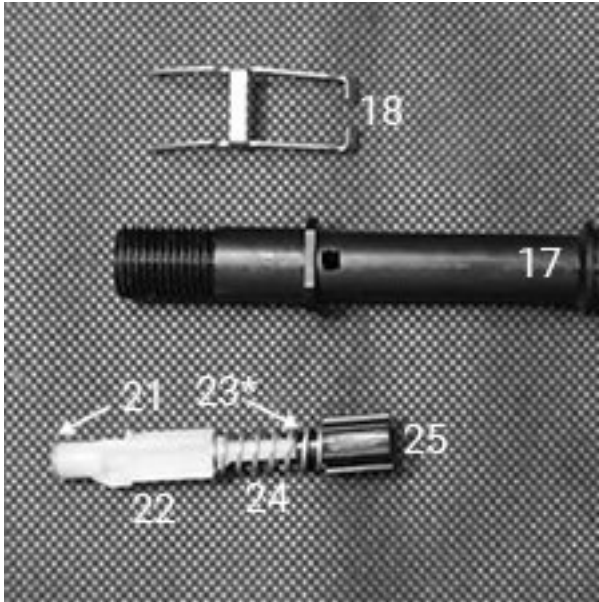

Fig. 15

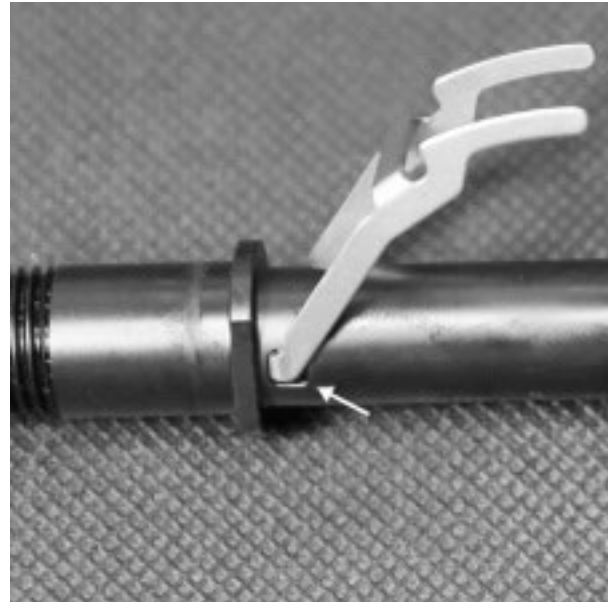

Fig. 16

7. Remove the LP Seat from the Piston. Pull the Piston and Main Spring out of the Balance Cylinder and remove the O-rings (23\*) from the Piston - Fig. 17.

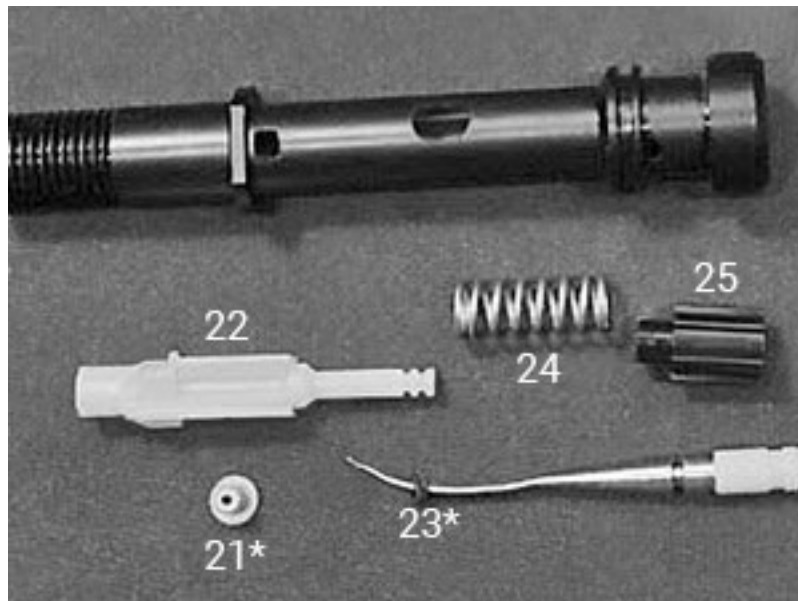

Fig. 17

8. Use the hex end of the In-Line Adjusting Tool or 3/16" hex wrench to loosen the Orifice (13) in the Adjust Tube. Push the Orifice out with a thin wooden dowel from the threaded end. Do not use a metal tool. Remove the O-ring (14\*) from the Orifice - Fig. 18.



Fig. 18

9. The disassembled Adjust Tube assembly with the Heat Sink Nut is shown below. Note that the O-ring (04\*) from under the Heat Sink Nut is similarly sized, but thicker than the O-ring (20\*) from the Adjust Tube - Fig. 19.



Fig. 19



10. With side-cutting snips, carefully cut the Tie Wrap (02\*) holding the Mouthpiece (03) - Fig. 20. Remove the Mouthpiece and check that the Main Housing (01), Exhaust Cover (12) and Exhaust Valve (11\*) are undamaged and free of debris. **The Exhaust Cover is not usually removed during service. The cover is fitted in such a way at the factory that removing it is likely to damage the Cover. Removal may also damage the flange that holds it in place - Fig. 21.**



Fig. 20



Fig. 21

If removal (to replace the Exhaust Valve) is necessary, soak the Main Housing and Exhaust Cover together in hot tap water for three minutes to soften the Cover. Then peel the wings from each side of the Main Housing flange and slide the Exhaust Cover down and off.

**This completes the disassembly of the D6 Second Stage.**

(4) The photographs below show the disassembled second stage - Fig. 22 and the Service Parts Kit - Fig. 23. All the parts not in the service kit need to be washed, rinsed and dried, as discussed previously. O-rings and washers that will be replaced with new from the service kit should be discarded.

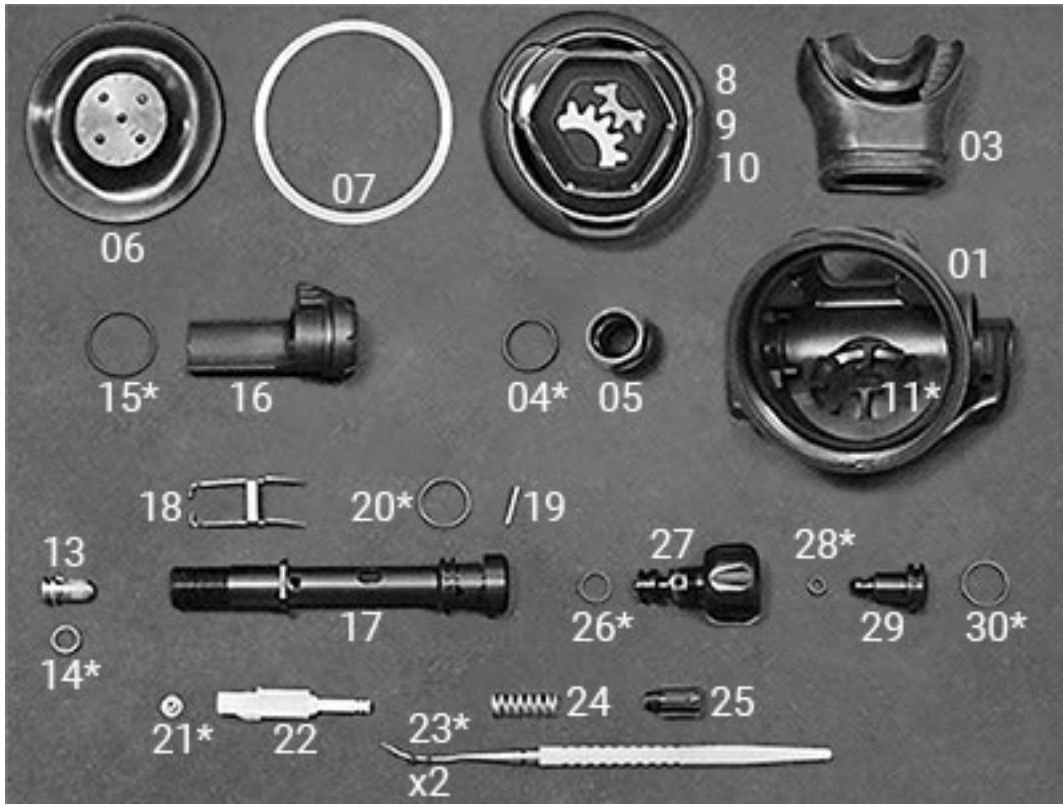

Fig. 22

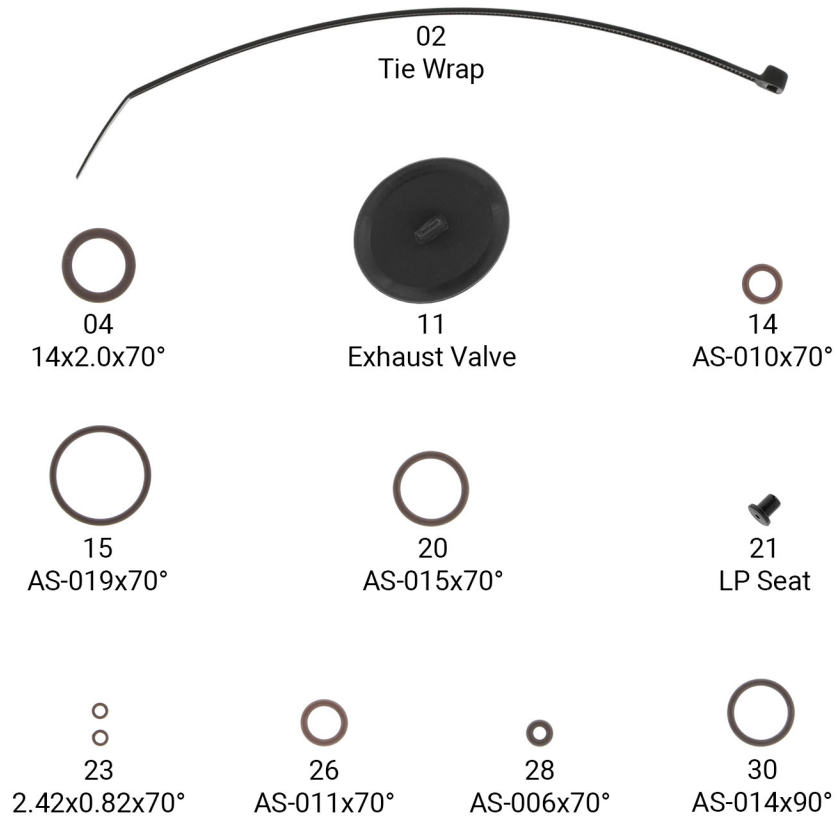

Fig. 23

## 6. Second Stage Assembly

(1) Additional tips for performing reassembly of the D6 Second Stage can be found in our video at:

<https://www.youtube.com/watch?v=allL4njr5kxl>

(2) Before starting the assembly of the second stage, complete a thorough inspection of all parts to be reused. Refer to the Overview Inspection section for details. At this time, open the service kit and lay out the parts. Use the schematic to identify each part.

**Caution Note:** Only use enough lubricant to lightly coat the O-rings and ensure no debris is trapped on them.

1. Install the LP Seat (21\*) into the end of the Piston (22). Note the orientation of the Step, which will be discussed in steps 6., 7. and 8. below - Fig. 24. Lubricate and install the O-rings (23\*) on the Piston - Fig. 25.

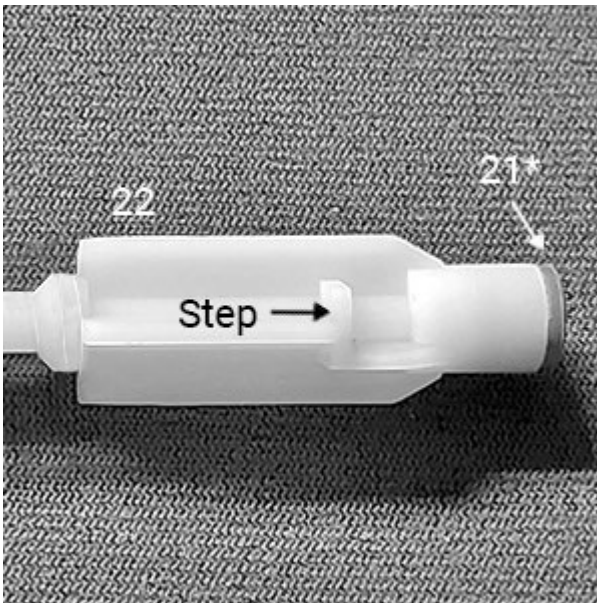

Fig. 24

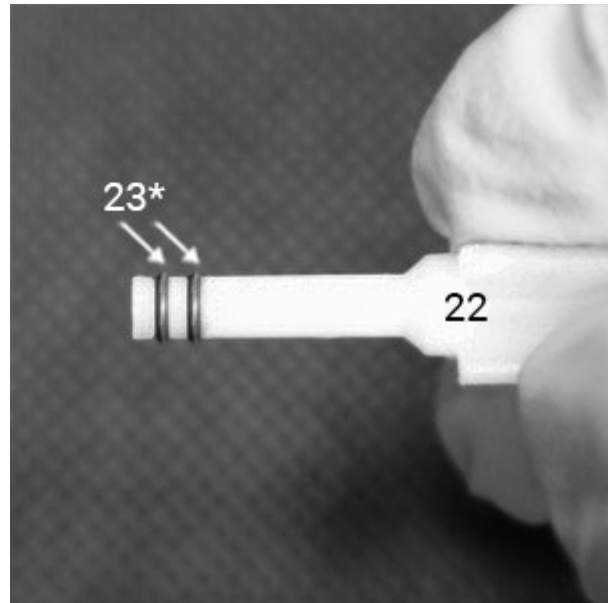

Fig. 25

2. Assemble the Balance Cylinder (25), Main Spring (24) and Piston as shown in Fig. 26.

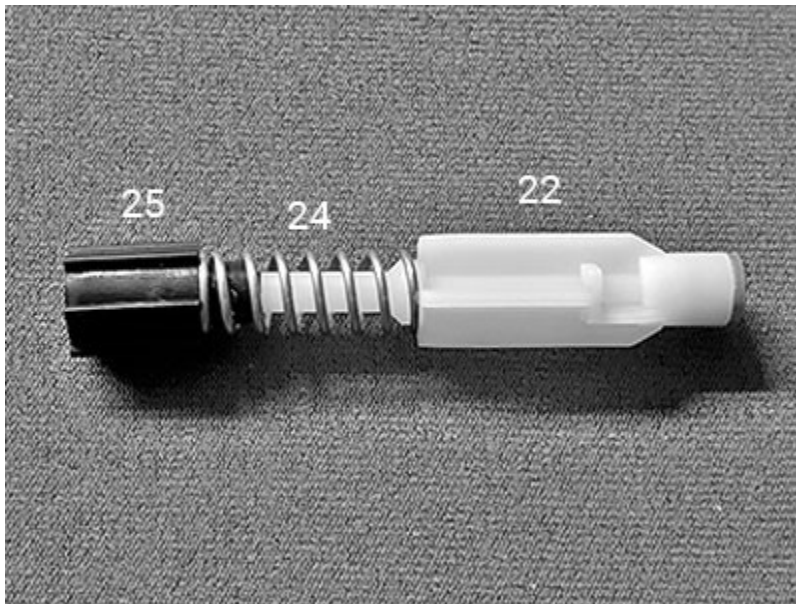

Fig. 26

3. Place the O-ring (14\*) on the Orifice (13) - Fig. 27. Insert the Orifice into the Adjust Tube (17) using the 3/16" hex - Fig. 28.



Fig. 27



Fig. 28

4. Turn the Orifice clockwise into the Adjust Tube 4-5 turns until the threads have engaged - Fig. 29.

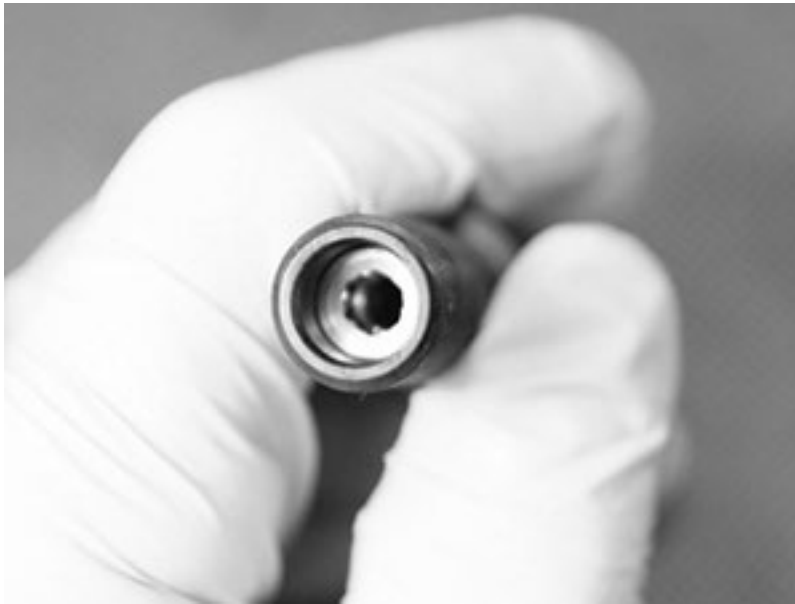

Fig. 29

5. Lubricate the O-ring (20\*) and place it in the groove on the Adjust Tube (17) - Fig. 30.



Fig. 30

6. Insert the Piston assembly (21\*-25\*) into the Adjust Tube, noting the step's orientation on the Piston and the air outlet of the Adjust Tube - Fig. 31. Fig. 32 shows how it should appear as the step passes the air outlet opening.

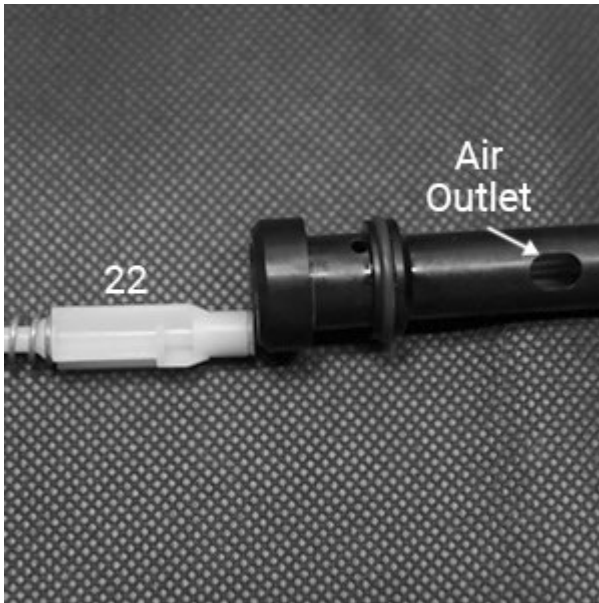

Fig. 31



Fig. 32

7. Slide the Piston assembly in until the step is seen in the Lever (18) opening - Fig. 33.



Fig. 33

8. Install the Lever, being careful to not rotate the assembly. Do not tilt the assembly as this may cause the Piston to move and the Lever not to engage the step - Fig. 34.

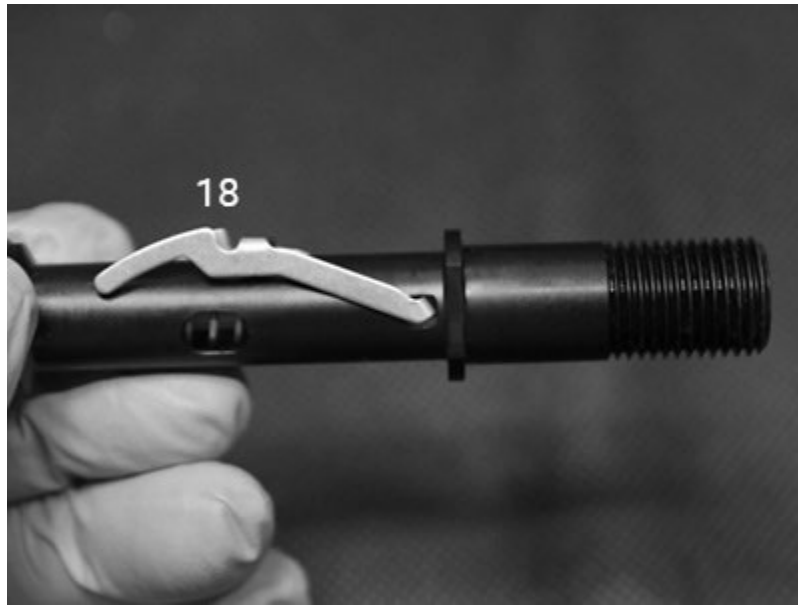

Fig. 34

9. Install the unlubricated O-rings (28\* and 30\*) on the Knob Adjust Core (29) and insert the Core in the Adjust Knob (27) and press into place. Then install the O-ring (26\*) on the Adjust Knob - Fig. 35.



Fig. 35

10. Take the assembled Adjust Knob - Fig. 36 and insert it into the Adjust Tube and begin to screw it in - Fig. 37.



Fig. 36



Fig. 37

11. Screw the Adjust Knob assembly into the tube until you can see clearly through the hole for the Pin (19). As the assembly is turned in, the Lever will rise - Fig. 38. If it does not, it may have become disengaged during the installation of the Lever. Remove and reinstall it as referenced in Step 8.

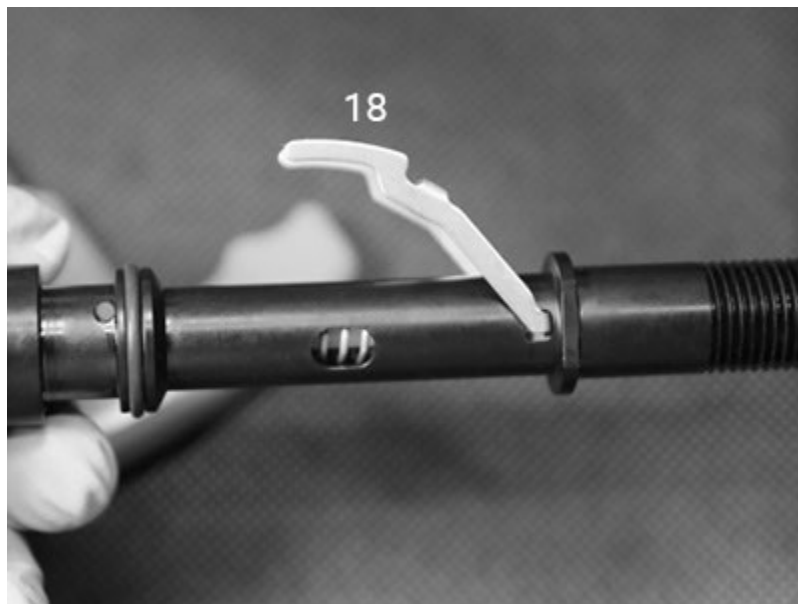

Fig. 38



12. Place the Pin into its hole once the Adjust Knob is screwed in far enough to see clearly through the opening - Fig. 39. Position the Pin evenly so that equal amounts are visible on each side - Fig. 40.



Fig. 39



Fig. 40

13. Lubricate the O-ring (15\*) and place it on the Deflector Knob (16) - Fig. 41.



Fig. 41

14. Hold the Lever down and slide the Deflector Knob over it onto the Adjust Tube - Fig. 42. Slide it on to cover the Pin - Fig. 43. Rotate the Deflector Knob and the Adjust Knob to ensure they move smoothly.



Fig. 42



Fig. 43

15. Slide the Adjust Tube assembly into the Main Housing (01) - Fig. 44. Make sure the assembly is all the way in, and the flat sides of the Lever's legs are in the notches in the Main Housing that prevent the Adjust Tube from rotating - Fig. 45.



Fig. 44

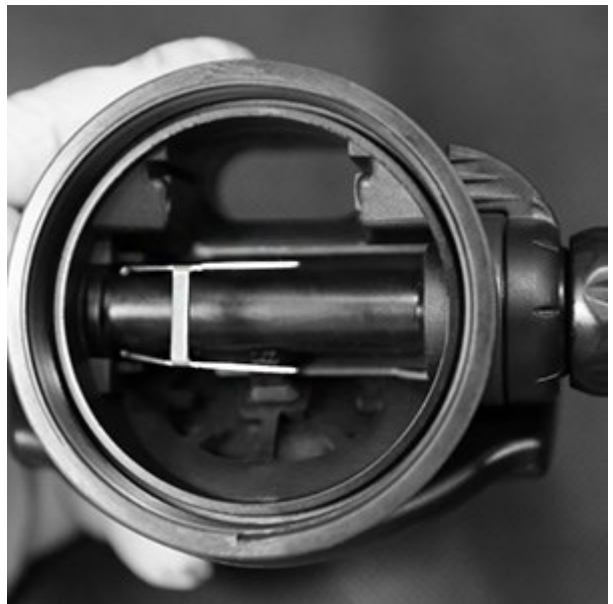

Fig. 45

16. Install the O-ring (04\*) and the Heat Sink Nut (05) on the Adjust Tube - Fig. 46.



Fig. 46

17. Carefully tighten the Heat Sink Nut to secure the Adjust Tube - Fig. 47. Do not overtighten.



Fig. 47

18. Using the In-Line Adjusting Tool, while depressing the Lever, turn the Orifice so that the Lever is barely above or even with the face of the Housing - Fig. 48. **Only turn the Orifice when the Lever is depressed to avoid cutting the LP Seat.** This is the preliminary adjustment of the cracking pressure. The final adjustment will be made with the tool when the second stage is pressurized.

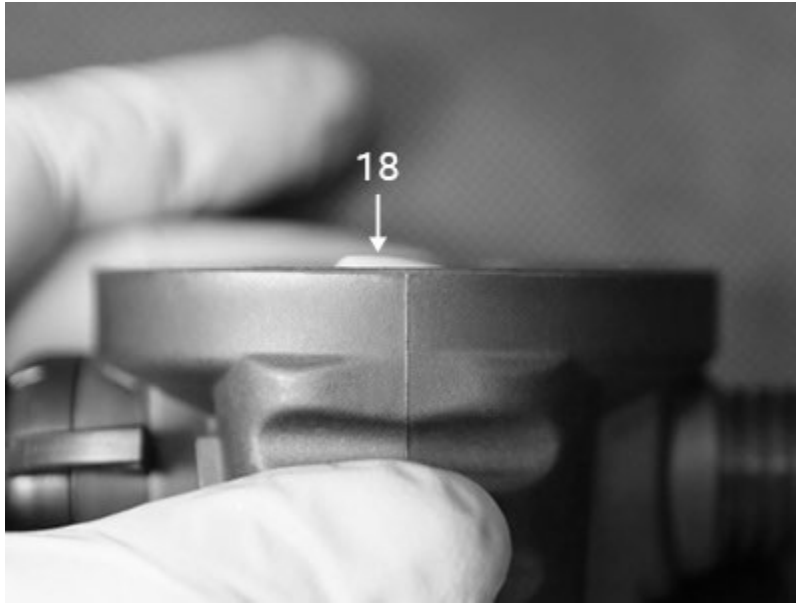

Fig. 48

19. Install the Diaphragm (06) - Fig. 49 and Diaphragm Washer (07) - Fig. 50.

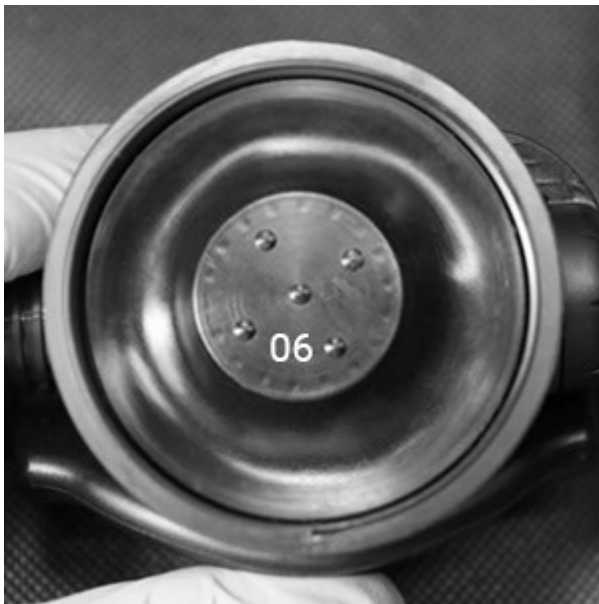

Fig. 49



Fig. 50

20. Install the Cover assembly (08, 09, and 10) - Fig. 51. Reinstall the Mouthpiece (03) and secure it with the Tie Wrap (02\*). Adjust as needed and use the snips to trim the end of Tie Wrap.



Fig. 51

This completes the assembly of the D6 Second Stage.

## 7. Second Stage Testing and Adjustment

(1) Second stage testing and adjustment can be accomplished by using a regulated supply or any cylinder of air. There is no required supply pressure due to the second stage being supplied by a first stage delivering air at the Intermediate Pressure (IP).

(2) Using a properly tuned first stage, connect the second stage to a low pressure hose with the Second Stage In-Line Adjusting Tool. Slowly pressurize the system with the purge button slightly depressed. Once the second stage starts to deliver air, release the purge button. It should not continue to flow. If it does, depressurize the system and adjust the Orifice using the In-Line Adjusting Tool. Turn the Orifice clockwise one-sixth turn to start. Retest. Depending on where the Orifice was initially set, it may be necessary to do this several times.

(3) If the second stage does not flow on the initial pressurization, attempt several normal breaths from it. If the breaths require significant effort, depressurize the system and with the purge button depressed turn the Orifice counterclockwise one-sixth turn and retest. As with the clockwise adjustment, this may need to be done several times.

(4) Once the second stage begins to deliver air at an acceptable level, it can be fine-tuned with the adjusting tool. While inhaling through the second stage, turn the tool's adjustment knob slightly in the required direction.

**Caution Note: To avoid excessive wear and cutting of the low pressure seat, only turn the Orifice using the In-Line Adjusting Tool with the purge button depressed by inhaling or by manually pressing it while making the adjustment.**

## 8. Testing for Cracking Effort

(1) Cracking effort is the suction required to depress the lever and allow air to flow through the second stage. It is measured in inches of water. A magnehelic gauge is one method of measuring this pressure. The gauge is attached to the second stage, and a normal breath is taken. The gauge measures the cracking pressure.

(2) Another method is to carefully submerge the second stage into a container of water and note where the air begins to flow using a ruler attached or held to the stage. This method is not always as accurate as using a magnehelic, but still yields acceptable results.

**Caution Note: Do not leave the In-Line Adjusting Tool attached when submerging the second stage. Connect the stage to the LP hose directly. The tool is meant for surface use only and submerging it may result in damage to the tool!**

(3) Cracking effort should initially be set at 1 to 1.2 inches of water. This will account for the decrease that will occur as the regulator is used. As the Seat begins to form the groove between it and the Orifice knife edge, cracking effort will decrease.

(4) General Troubleshooting – Not all possibilities may be noted.

No airflow	Check supply pressure; Orifice too tight; Lever not seated and has dropped
Free Flowing	Orifice adjusted too loosely; LP Seat bad; excessive IP
Hard to inhale	Lever bent or restricted; adjusted with a too high cracking pressure
Wet breathing	Cracked Main Housing; bad Exhaust Valve; bad Diaphragm
Purge Button hard to press	Debris in Purge Button; bad Spring



# DIVE GEAR EXPRESS

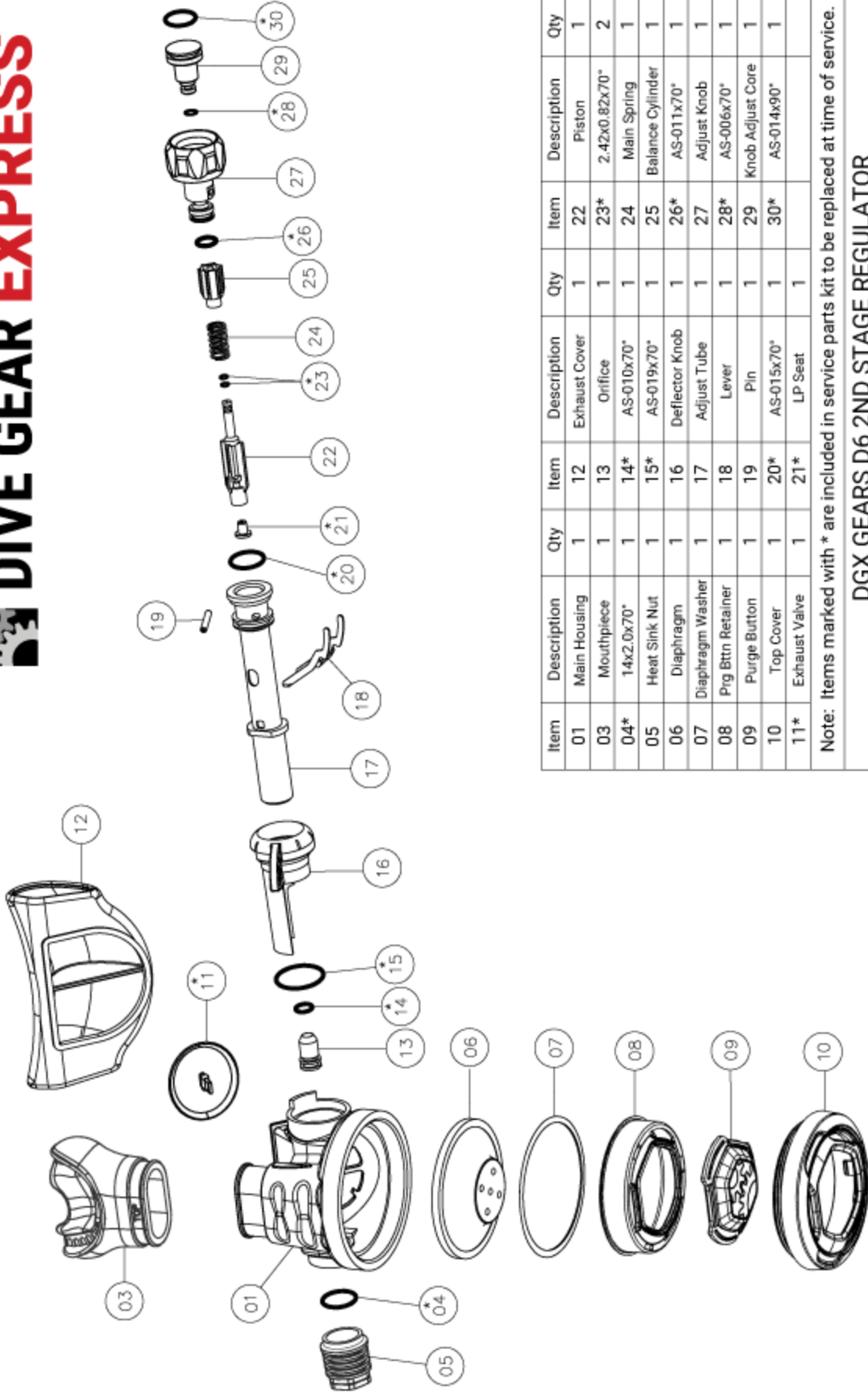

Item	Description	Qty	Item	Description	Qty	Item	Description	Qty
01	Main Housing	1	12	Exhaust Cover	1	22	Piston	1
03	Mouthpiece	1	13	Orifice	1	23*	2.42x0.82x70*	2
04*	14x2.0x70*	1	14*	AS-010x70*	1	24	Main Spring	1
05	Heat Sink Nut	1	15*	AS-019x70*	1	25	Balance Cylinder	1
06	Diaphragm	1	16	Deflector Knob	1	26*	AS-011x70*	1
07	Diaphragm Washer	1	17	Adjust Tube	1	27	Adjust Knob	1
08	Prg Btn Retainer	1	18	Lever	1	28*	AS-006x70*	1
09	Purge Button	1	19	Pin	1	29	Knob Adjust Core	1
10	Top Cover	1	20*	AS-015x70*	1	30*	AS-014x90*	1
11*	Exhaust Valve	1	21*	LP Seat	1			

Note: Items marked with \* are included in service parts kit to be replaced at time of service.

DGX GEARS D6 2ND STAGE REGULATOR

DX-200001